

## Toward Defining Key Success Factors of E-Government and Accounting Information Quality: Case of Indonesia

Hamzah Ritchi\*, Sylvia Fettry and Azhar Susanto

Faculty Economic and Business, Padjadjaran University, Bandung, Indonesia

### Abstract

The e-Government implementation objective is to achieve clean, transparent, and responsive government. The information technology elements integration will be needed on each business processes stage such that great number of services within public services sphere are attributed with an accurate, timely, complete, and relevant information. Despite efforts that have been devoted on e-Government, the performance on such initiative is relatively unsubstantiated. This may lead to low quality of accounting information as reflected in the modified audit opinion for some municipalities' financial statement.

This research program is conducted to measure the e-Government implication on the accounting information quality which is measured by financial statement quality, in order to set strategy for gaining unqualified opinion on municipalities' financial statement, in particular West Java Province. The Province of West Java, Indonesia has been paying much attention on e-Government implementation for a decade. However, the 2012 PEGI result (Indonesia e-Government Ranking) for 21 municipalities in West Java Province are still poor. This research will identify a relation model between them.

The multi-year triangulation is conducted in 27 municipalities of West Java Province. The research employs different sets of research approaches such as structured review and qualitative work with interview or focus group discussion to develop key success factors of e-Government, and Partial Least Squares Structural Equation Modeling to verify the structured factors.

**Keywords:** Information system; Accounting information quality; E-Government; Key success factors

### Introduction

In the modern digital era, massive amounts of investment in Information and Communications Technology (ICT) is very important to keep the feasibility of public sector services [1]. ICT investment of Indonesian Government continues to be a major component of capital investment approximately Rp 14 trillion (US\$ 1,2 billion) in 2013 and Rp 36 trillion (US\$ 2,8 billion) in 2014 [2]. However, such amount is still less than developed countries such as Great Britain \$518 million, Singapore \$800 million, and Australia \$5,97 billion in [2]. This ICT investments related with e-Government will be tended to grow over time [1]. Investment growth in ICT is not an option but a must to make it possible to develop and deploy e-Government services efficiently and effectively for governments and public administration to realize the benefits of ICT to not fall behind [3]. Early e-Government initiatives during the late 1990s focused on the widespread application of ICT for the production and dissemination of information; putting as much information and as many services online as possible was the measure of success [4]. But now it is entering a new episode [5]. Today, governments have begun to integrate e-Government into the effort to ensure better and more modern government, to benefit all aspects of government operations, not just those explicitly related to the use of ICT [4]. The primary goal of e-Government is adding public value and the emphasis is now being placed on deploying a portfolio of e-services that spans functions, business units and geographies, at varying local or municipal levels, thus increasing the value of service offerings to citizens by effectively adopting disruptive technologies in an adaptive and scalable manner [5]. E-Government in Indonesia has been initiated by Presidential Instruction No. 6/2001 (dated 24 April 2001) on Telecommunication, Media, and Information (called as "Telematika" in bahasa) which states that each government institution should use the technologies of Telematika to support good governance and to

accelerate democratic processes [6]. Presidential Instruction No. 3/2003 on National Policy and Strategic Development of e-Government [7] further provides a technical guide for developing e-Government, such as portal infrastructure, documentation system, e-Government manuals, local government's website maintenance. The Act Number 11/2008 on Electronic Transaction and Information has been legislated the basic rules for conducting electronic transactions. That legal umbrella is very important for Indonesia doing its e-Government initiatives at both the central and local governments. Since 2002, 69 central government agencies and 403 local governments have launched official websites as an early stage development of e-Government. Although most of the developments still remain at the level of information delivery, some provincial governments have progressed into the transactional stage so as to increase the local revenue. Based on 2014 UN survey, Indonesia get ranking of 106 and grouped in middle e-Government development index (EGDI) (0.4487 which is between 0.25-0.50 of 1.00), with online service index 0.3622, telecommunication infrastructure index 0.3054, and e-participation index 0.2941. It is a good achievement for Indonesia as a developing country. However, in comparison to the e-Government in the European Union countries, Indonesia is still far behind [8]. Besides, comparable to other ASEAN countries, yet Indonesia's e-government level is still lower than Singapore, Malaysia, Thailand,

\*Corresponding author: Hamzah Ritchi, Faculty Economic and Business, Padjadjaran University, Bandung, Indonesia, Tel: +62 22 84288828; E-mail: hamzahritchi@fe.unpad.ac.id

Received December 23, 2015; Accepted April 27, 2016; Published May 05, 2016

**Citation:** Ritchi H, Fettry S, Susanto A (2016) Toward Defining Key Success Factors of E-Government and Accounting Information Quality: Case of Indonesia. Int J Account Res 4: 126. doi:10.4172/2472-114X.1000126

**Copyright:** © 2016 Ritchi H, et al. This is an open-access article distributed under the terms of the Creative Commons Attribution License, which permits unrestricted use, distribution, and reproduction in any medium, provided the original author and source are credited.

Philippines and Brunei Darussalam. According to the Center for Public Management Studies (2009) National Institute of Public Administration (NIPA), there are four important issues related with weaknesses in e-Government implementation policies of Indonesia as following: (1) e-Government services are not supported yet by the effective management systems and work processes, (2) there is inadequate budget allocation and lack of strategic planning for the development of e-Government in each government institution, (3) there is a lack of coordination among the government institutions, and (4) the approach taken by individual institution is not strong enough to overcome the gap community's ability to access the internet network, so that many public services are developed to be limited as well. A nationwide survey, called as "Indonesia e-Government Ranking (PEGI)," has been conducted annually since 2008 to rank the developmental levels of e-Government of both national and local governments [8]. PEGI is expected to enhance the development and utilization of ICT in government agencies. This survey can diagnose the strengths and weaknesses of all the governmental institutions and provide useful information for the further development of ICT in Indonesia. The 2012 PEGI result shows that the assessment of each dimension (policy, institutional, infrastructure, applications, and planning) for 21 municipalities in West Java Province, Indonesia in average are arguably still yet to be optimize [9]. 71.42% of the implementation is being regarded as inadequate with the other 19.04% is categorized as even worse. This poor perceptual assessment may lead to and be attributed to low quality of accounting information as reflected in the modified audit opinion for some municipalities' financial statement. Hence, this conceptual paper aims at acquiring better understanding on the effectiveness of e-Government and utilizing this knowledge as a benchmark to identify the key success factors of current and future implementation of the local government. This is a preliminary research program which shall be part of a multi-year work. The proposed research model is developed to measure the implication of the e-Government implementation on the quality of accounting information. The final output of this research program is a comprehensive strategy for gaining unqualified opinion on municipalities' financial statement in West Java Province, Indonesia. The desired outcomes of this research program are to provide conceptual basis to better comprehend the effectiveness of e-Government and to provide applicable input for developing public policy to support its effectiveness. This paper discusses the preliminary research program for a multi-years and presented as following. Section 2 provides literature review about e-Government, its key succes factors, financial statement quality, and the theoretical framework. Section 3 describes the methodology consists of research methods, operationalization of the variables, population, and analysis method. Section 4 contains the research model to conducted for multi-years. Section 5 is conclusion and future work.

## Literature Review

### Electronic government (e-Government)

As mentioned earlier that the implementation of e-Government can support and improve government performance in public sector services. Currently, e-Government has been developed in various countries both developed and developing countries. E-Government refers to the delivery of government information and communication technologies, and particularly the Internet, as a tool to achieve better [10]. It is about delivering improved services to citizens, businesses, and other members of the society through drastically changing the way governments manage information [11]. Generally, e-Government has been defined as the application of ICTs to transform the efficiency,

effectiveness, transparency and accountability of informational and transactional exchanges within government units, between government units at state and local levels, citizens and businesses; and to empower citizens through access and use of public information and public services [12].

The targets of e-Government by the Ministry of Communications and Information Technology [13] are:

- 1) The establishment of a high quality and affordable network of information and public sector services transaction quality.
- 2) Establishment of an interactive relationship with the business community to improve and strengthen the economy's ability to encounter changes in international trade and competition.
- 3) The establishment of a communication mechanism among government agencies and the provision of facilities for public participation in the governance process.
- 4) Establishment of management systems and work processes are transparent and efficient, and facilitate transactions between government agencies and services.

### Critical success factors of e-government adoption

An important challenge is to identify factors that determine the success of e-Government adoption. Success factors are areas and operations which should be focused on primarily in order to achieve the most satisfying results of e-Government adoption [14]. E-Government has become a multidisciplinary field of research. In addition to computer science, there are several other disciplines in the e-Government such as public administration, management, political, social, cultural, etc. Although the theoretical foundations of e-Government is still being developed, but the e-Government has been qualified as a new discipline [15]. Heeks [16] states that e-Government is an information system, which can be described as a socio-technical systems. A socio-technical system means a combination of social and technological aspects [17]. Information systems quality is an important measures of IS success [18]. There are two models of the information systems success. (1) The D & M of Information Success Model [19] and The D & M of Information Success: A Ten-Year Update [20] developed by DeLone and McLean, and (2) Technology Acceptance Model (TAM) that is developed by Davis [21]. The model developed by DeLone and McLean [19,20] have been used extensively in research in the field of information systems. In 1992 model [19], there are 6 (six) the variable component of the success of information systems: (1) system quality, (2) information quality, (3) use, (4) user satisfaction, (5) individual impact, and (6) organizational impact. These components are not independent variables but as mutually dependent (interdependent) of each other. Figure 1 below shows the original D & M of Information Systems Success Model: (Figure 1) Models of the information systems success can also be explained by using a successful model of other systems, namely the Technical Acceptance Model (TAM) developed by Davis [21]. TAM, as shown in (Figure 2) illustrates the factors that lead to the acceptance and actual usage technology at the highest level. TAM detailing factors that can drive the best attitude to information systems together with the receipt and use of the system is the highest in the organization. The factors in question are usefulness, ease of use, quality of information system, and degree to which the organization supports its use [22], (Figure 2) Stair and Reynold [23] stated that a quality information system is usually flexible, efficient, accessible, and timely. Next, Laudon & Laudon [24] explain that an information system that blend technical efficiency with sensitivity to organizational and human

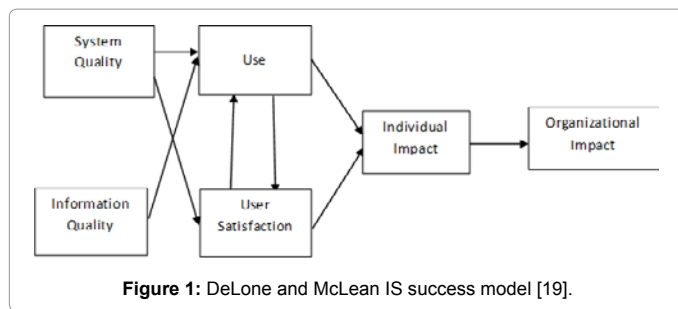

Figure 1: DeLone and McLean IS success model [19].

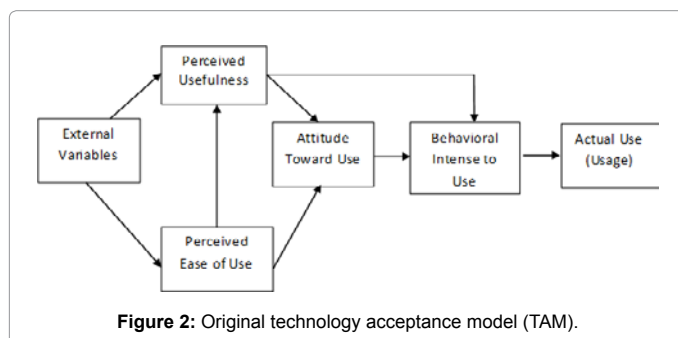

Figure 2: Original technology acceptance model (TAM).

needs, leading to higher job satisfaction and productivity [25] state that the quality characteristics of information system are utility, reliability, efficiency, customization and flexibility. Heidmann [26] measures the success of the system based on integration, flexibility, accessibility, formalization dan media richness.

### Financial statement quality

Information quality discussed in this paper is about the financial statement quality as the result of financial reporting. The objective of financial reporting is to provide high-quality financial reporting information concerning economic entities, primarily financial in nature, useful for economic decision making [27]. Many researchers measure the quality of financial reporting indirectly by focusing on attributes that are believed to influence quality of financial reports, such as earnings management, financial restatements, and timeliness [28]. With regards to the financial statement quality, Belkaoui [29] states that the qualitative characteristics of financial statement should be largely upon the needs of users of the statement. Information should be free as possible from any biases of the preparer. In making decision users should not only understand the information presented, but should be able to assess its reliability and compare it with information about alternative opportunities and previous experience. In all information is more useful if it stresses economic substance rather than technical form. The qualitative characteristics of financial statements are normative measures that need to be realized in the accounting information so that it can achieve its purpose. The characteristics which is a prerequisite normative for the financial statements of government can meet the desired quality according based on Standard Akuntansi Pemerintahan (SAP) as regulated in Government Regulation No. 71/2010 [30], namely:

- 1) Relevance;
- 2) Reliability (faithful representation);
- 3) Comparability; and
- 4) Understandability.

Financial and non-financial information is relevant if it is capable of making a difference in achieving the objectives of financial reporting. Financial and non-financial information is capable of making a difference when it has confirmatory value, predictive value, or both. It may be capable of making a difference, and thus be relevant, even if some users choose not to take advantage of it or are already aware of it [31]. To be useful in financial reporting, information must be a faithful representation of the economic and other phenomena that it purports to represent. Faithful representation is attained when the depiction of the phenomenon is complete, neutral, and free from material error. Information that faithfully represents an economic or other phenomenon depicts the substance of the underlying transaction, other event, activity or circumstance which is not necessarily always the same as its legal form [31]. Comparability is the quality of information that enables users to identify similarities in, and differences between, two sets of phenomena. Comparability is not a quality of an individual item of information, but rather a quality of the relationship between two or more items of information form. Understandability is the quality of information that enables users to comprehend its meaning. General Purpose of Financial Reports (GPFs) of public sector entities should present information in a manner that responds to the needs and knowledge base of users, and to the nature of the information presented.

### Theoretical framework

Theoretical framework designed in this study is that the information quality (measured by financial statements quality) is influenced by success factors of e-Government [16] positions e-Government as an information system. This is supported by the result of the study showing that there is a relationship between information system to report on the basis of information quality characteristics [32]. Next, [33] states, that the effectiveness of the information system is measured by the satisfaction of the decision makers on the information quality produced by the information system success, and information system enhances the truth of financial statements [34].

### The Metodology

#### Research methods

Research methods refer to the methods the researchers use in performing research operations. In other words, all those methods which are used by the researcher during the course of studying his research problem are termed as research methods [35].

The methods that will be used in this research are as follows:

Based on the research objectives, this research is survey research. According to Sekaran and Bougie [36] survey method can be done by collecting information from people who act as resources that can be described, compared and explained the facts relating to people, events or certain situations. Nazir [37] adds with a survey method, the researchers not only provides a description of phenomena, but also explain the relationship, test hypotheses, make predictions, and get the meaning and implications of a problem to be solved. This research can provide a picture of the phenomena associated with the successful implementation of e-Government and the quality of financial statement in West Java Province.

Based on the type of investigation, this kind of research is verificative research and causal explanatory research. According to [38], the emphasis of explanatory study is to learn the situation or problem to explain the influence between variables. Furthermore, [36]

state that researchers are interested in causal research to describe one or more factors that cause problems.

Based on the setting, this research is a field study with a minimal involvement of researchers [36].

### Operationalization of the variables

Operationalization of the variables is the process of operationalizing the concept becomes a variable that can be measured, which is formulated by basing on the concept owned dimensions and then categorized on the elements that can be measured [36]. Based on this statement, the operationalization of each variable in this research are as follows:

1) External factors that affect perceived usefulness and perceived ease of use which can be influence the successful implementation of e-Government. These factors will further obtained by the method of qualitative research through systematic papers and content analysis.

2) Perceived usefulness refers to the degree to which a person believes that using a particular system would enhance his or her job performance. The indicators used to measure this dimension are: work more quickly, job performance, effectiveness, makes job easier [39,40].

3) Perceived ease of use, refers to the degree to which a person believes that using a particular system would be free effort. The indicators used to measure this dimension are: easy to learn, easy to become skilful, easy to use, easy to remember [39,40].

4) Intention to Use Information and Information system (IS) use (usage), refers to a manner in which a person utilizes the capabilities of an information systems. The indicators used to measure this dimension are: frequency of use and hours of use [40,41].

5) The quality of financial statements is measured by relevance, reliability, comparability and understandability [28,30]:

a) Relevance, refers to the timeliness of presenting information/reports and completeness of data/information. The indicators used to measure this dimension are: feedback value, predictive value, timeliness, and complete.

b) Reliability, refers to the error rate of information presentation or documents supporting ownership data / transactions and others. The indicators used to measure this dimension are a faithful representation and verifiability.

c) Comparability, refers to the disclosure of the use of different accounting methods from the previous period. The indicators used to measure this dimension are: consistency and disclosure.

d) Understandability, refers to the user's understanding of the term accounting information systems, engineering, and accounting methods used. The indicators used to measure this dimension are: use the appropriate term and intelible form.

The indicators in this research will be measured by a Likert scale on a five-point scale.

### Population

Population in this research are all cities and districts in the province of West Java, that is: (1) Kabupaten Bandung, (2) Kabupaten Bandung Barat., (3) Kabupaten Bekasi, (4) Kabupaten Bogor, (5) Kabupaten Ciamis, (6) Kabupaten Cianjur, (7) Kabupaten Cirebon, (8) Kabupaten Garut, (9) Kabupaten Indramayu, (10) Kabupaten Karawang, (11) Kabupaten Kuningan, (12) Kabupaten Majalengka, (13) Kabupaten

Pangandaran, (14) Kabupaten Purwakarta, (15) Kabupaten Subang, (16) Kabupaten Sukabumi, (17) Kabupaten Sumedang, (18) Kabupaten Tasikmalaya, (19) Kota Bandung, (20) Kota Banjar, (21) Kota Bekasi, (22) Kota Bogor, (23) Kota Cimahi, (24) Kota Cirebon, (25) Kota Depok, (26) Kota Sukabumi, and (27) Kota Tasikmalaya.

### The analysis method

The analysis method that will be used in this research is Partial Least Squares Structural Equation Modeling (PLS-SEM). PLS-SEM works efficiently with small sizes and complex models and makes practically no assumptions about the underlying data. In addition, PLS-SEM can easily handle relative and formative measurement models, as well as single-item constructs, with no identification problems. It can therefore be applied in a wide variety of research situations. PLS-SEM is more likely to render a specific relationship significant when it is in fact significant in the population [42]. The stages analysis in PLS methods are suggested by [43]:

- 1) Designing structural models (inner model).
- 2) Designing a measurement model (outer model).
- 3) Construction path diagram.
- 4) Conversion path diagram into a system of equations.
- 5) Evaluation of Goodness of Fit.

### Proposed Research Model

The research model is developed in a structural model and measurement model. Structural models (inner model) in this research consist of an exogenous latent variables, namely the success factors of the implementation of e-Government, and four endogenous latent variables, namely the perceived usefulness, perceived ease of use, information system use (usage), and quality of financial reporting. Relationships between the latent variables are causal. Measurement model (outer model) is a model that connects the latent variables with manifest variables. The first latent variables, factors of success of the implementation of e-Government, will be investigated further with qualitative methods. The next latent variables, perceived usefulness consists of four manifest variables, perceived ease of use consists of four manifest variables, information system usage consists of two variables manifest, and the quality of financial statements consists of four variables manifest. Structural model (inner model) and measurement model (outer model) are combined to construct the path diagram. Based on the research model, the path diagram of the variables can be illustrated as in (Figure 3).

Where:

SFeG=Success Factors of e-Government Implementation (variables that will be investigated with qualitative methods)

PU=Perceived Usefulness

PEU=Pereived Easy of Use

ISU=Information System Use (Usage)

FSQ=Financial Statements Quality

$\gamma_{1,i}$ =Gamma, path coefficients of latent exogenous variables on the latent variables PU and PEU

$\beta_{n,i}$ =Beta, path coefficients of PU, PEU on ISU and ISU on FSQ

$\lambda$ =Lambda, weighting factor of each indicator

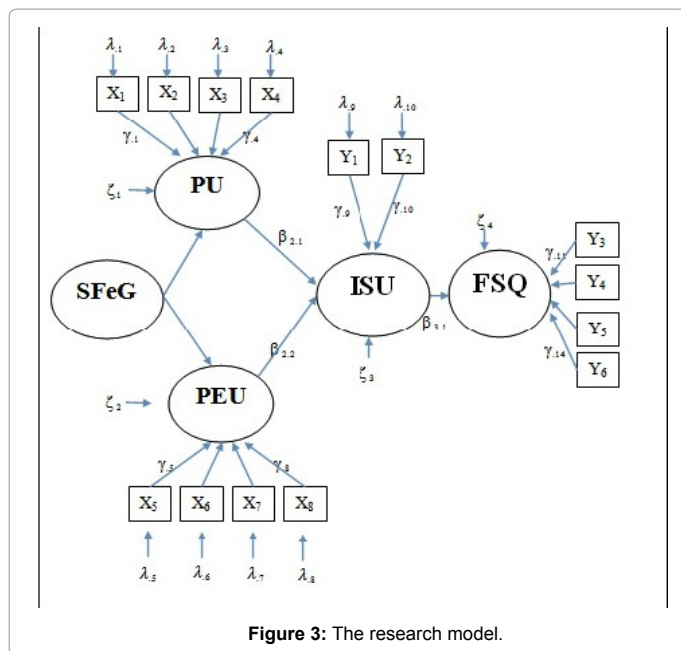

Figure 3: The research model.

$\zeta$ =Zeta, the influence of other factors

Path diagram in Figure 3 can be formulated into the form of structural equation as follows:

$$PU = \gamma_{1.1} SFeG + \zeta_1 \quad (1)$$

$$PEU = \gamma_{1.2} SFeG + \zeta_2 \quad (2)$$

$$ISU = \beta_{2.1} PU + \beta_{2.2} PEU + \zeta_3 \quad (3)$$

$$FSQ = \beta_{3.1} ISU + \zeta_4 \quad (4)$$

Furthermore, the measurement equation latent variables in this research are translated as follows:

1) Measurement model for PU

$$PU_1 = \gamma_1 X_1 + \delta_1$$

$$PU_2 = \gamma_2 X_2 + \delta_2$$

$$PU_3 = \gamma_3 X_3 + \delta_3$$

$$PU_4 = \gamma_4 X_4 + \delta_4$$

2) Measurement model for PEU

$$PEU_1 = \gamma_5 X_5 + \delta_5$$

$$PEU_2 = \gamma_6 X_6 + \delta_6$$

$$PEU_3 = \gamma_7 X_7 + \delta_7$$

$$PEU_4 = \gamma_8 X_8 + \delta_8$$

3) Measurement model for ISU

$$ISU_1 = \gamma_9 Y_1 + \epsilon_1$$

$$ISU_2 = \gamma_{10} Y_2 + \epsilon_2$$

4) Measurement model for FSQ

$$FSQ_1 = \gamma_{11} Y_3 + \epsilon_3$$

$$FSQ_2 = \gamma_{12} Y_4 + \epsilon_4$$

$$FSQ_3 = \gamma_{13} Y_5 + \epsilon_5$$

$$FSQ_4 = \gamma_{14} Y_6 + \epsilon_6$$

The overall model will be validated using Goodness of Fit (GoF). GoF index is a single measure that is used to validate the performance of a combination between the measurement models (outer model) and structural models (inner model).

## Conclusion and Future Work

In summary, within the execution of this research program we expect to derive with the identified relation model between the e-Government implementation and the accounting information quality for future development and a more wealthy research data collected from different range of qualitative data. This research program will be a multi-years research and conducted in four years. The first year is to develop the research program. The second year is to find the success factor of e-Government in a qualitative work. The third year is to test the research model (structural and measurement model) in PLS method analysis. Finally, the fourth year is to build the strategy for gaining unqualified opinion on municipalities' financial statement in West Java Province, Indonesia and to realize the desired outcome such as a conceptual basis to better comprehend the effectiveness of e-Government, an applicable input for developing public policy to support its effectiveness, and a higher competence and integrity of human resources as the users of e-Government.

## References

- Dunleavy P, Margetts H, Bastow S, Tinkler J (2006) *Digital Era Governance: IT Corporations the State and E-Government*: Oxford University Press.
- Anggono ID (2015) *E-Government Indonesia Update*. Ministry of Communication and Information Technology the Republic of Indonesia Jakarta.
- Baqir MN, Iyer L (2010) *E-government Maturity Over 10 Years: A Comparative Analysis of E-Government Maturity in Select Countries Around the World in Comparative E-Government*, pp: 3-22.
- Organisation for Economic Co-operation and Development (2005) *E-Government for Better Government Paris*: OECD.
- United Nations E-Government Survey (2014) *E-Government for the Future We Want*. United Nations Department of Economic and Social Affairs New York.
- The Republic of Indonesia Presidential Instruction (2001) *The Republic of Indonesia Presidential Instruction on Telecommunication Media and Information*.
- The Republic of Indonesia Presidential Instruction (2003) *The Republic of Indonesia Presidential Instruction on National Policy and Strategic Development of e-Government*.
- Organisation for Economic Co-operation and Development (2014) *Advancing Indonesia Local e-Government: Challenges Opportunities and Strategic Roadmap*. Seoul: OECD Korea Policy Centre.
- Direktorat e-Government (2012) *Pemeringkatan e-Government Indonesia Kabupaten/Kota di Wilayah Provinsi Jawa Barat Tahun*.
- Organisation for Economic Co-operation and Development Organisation for Economic Co-operation and Development (2003) *The e-Government Imperative*.
- Accenture (2006) *The Government Executive Series: E-Government Leadership Realising the Vision*.
- Ziemba E, Papaj T, Zelazny R (2013) *A Model of Success Factors for E-Government Adoption-The Case of Poland*. *Issues in Information Systems* 14: 87-100.
- Ministry of Communications and Information Technology (2014) *Cetak Biru (Blueprint) Sistem Aplikasi e-Government Bagi Lembaga Pemerintah Daerah*. Ministry of Communication and Information Jakarta.
- Ziemba E, Papaj T (2012) *E-Government Application at the Regional Level in*

- Poland-The Case of SEKAP in Computer Science and Information Systems. (FedCSIS) Federated Conference, pp: 47-1054.
15. Assar S, Boughzala I, Boydens I (2011) Back to Practice a Decade of Research in E-Government: Springer.
  16. Heeks R (2005) Implementing and Managing Government: An International Text.
  17. Avison D, Wood T (2003) Bringing Social and Organisational Issues into Information Systems Development: The Story of Multitier. *Socio-Technical and Human Cognition Elements of Information Systems*, pp: 5-21.
  18. Gorla N, Somers TM, Wong B (2010) Organizational Impact of System Quality Information Quality and Service Quality. *The Journal of Strategic Information Systems* 19: 207-228.
  19. DeLone WH, McLean ER (1992) Information Systems Success: The Quest for the Dependent Variable. *Information systems research* 3: 60-95.
  20. DeLone WH, McLean ER (2003) The DeLone and McLean Model of Information Systems Success: A Ten-Year Update. *Journal of management information systems* 19: 9-30.
  21. Davis FD (1989) Perceived Usefulness Perceived Ease of Use and User Acceptance of Information Technology. *MIS Quarterly* 13: 319-340.
  22. Stair R, Reynolds G (2013) Fundamentals of Information Systems Cengage Learning.
  23. Stair RM, Reynolds GW (2013) Principles of Information Systems. New York Course Technology Mc-Graw-Hill.
  24. Laudon KC, Laudon JP (2014) Management Information Systems: Managing the Digital Firm. America: Pearson/Prentice Hall.
  25. Horan TA, Abhichandani T (2006) Evaluating User Satisfaction in an E-Government Initiative: Results of Structural Equation Modelling and Focus Group Discussions. *Journal of information technology management* 17: 33.
  26. Heidmann M (2008) The Role of Management Accounting Systems in Strategic Sense Making: Springer.
  27. International Accounting Standards Board. Exposure Draft on an Improved Conceptual Framework for Financial Reporting (2008) The Objective of Financial Reporting and Qualitative Characteristics of Decision-useful Financial Reporting Information. IASB London.
  28. Van BF, Braam G, Boelens S (2009) Quality of Financial Reporting: measuring qualitative characteristics. Nijmegen Center for Economics (NiCE) Working Paper, pp: 9-108.
  29. Riahi BA (2004) Accounting theory: Cengage Learning EMEA.
  30. The Republic of Indonesia Government Regulation (2010) The Republic of Indonesia Government Regulation on Standar Akuntansi Pemerintahan.
  31. International Public Sector Accounting Standards Board (2013) The Conceptual Framework for General Purpose Financial Reporting by Public Sector Entities Including National Regional and Local Governments and Related Governmental Agencies.
  32. Mamic I, Zager K, Tusek B (2003) Accounting Information System's Quality as the Ground for Quality Business Reporting in Barcelona Spain. IADIS International Conference E-Commerce.
  33. Nicolaou AI (2000) A Contingency Model of Perceived Effectiveness in Accounting Information Systems: Organizational Coordination and Control Effects. *International Journal of Accounting Information Systems* 1: 91-105.
  34. Salehi M, Rostami V, Mogadam A (2010) Usefulness of Accounting Information System in Emerging Economy: Empirical Evidence of Iran. *International Journal of Economics and Finance* 2: 186.
  35. Kothari C (2004) Research Methodology: Methods and Techniques. New Age International.
  36. Sekaran U, Bougie R (2010) Research Methods for Business: A Skill Building Approach. John Wiley & Sons.
  37. Nazir M (2011) Metode Penelitian Jakarta.
  38. Saunders M, Lewis P, Thornhill A (2009) Research Methods for Business Students. Harlow: Financial Times Prentice Hall.
  39. Davis GB, Olson MH (1984) Management Information Systems: Conceptual Foundations Structure and Development: McGraw-Hill.
  40. Adams AD, Nelson RR, Todd PA (1992) Perceived Usefulness Ease of Use and Usage of Information Technology: A Replication. *MIS quarterly* pp: 227-247.
  41. Petter S, DeLone W, McLean E (2008) Measuring information Systems Success: Models Dimensions Measures And Interrelationships. *European journal of information systems* 17: 236-263.
  42. Hair J, Black W, Babin B, Anderson R (2010) Canonical Correlation: A Supplement to Multivariate Data Analysis Upper Saddle River: Pearson Prentice Hall Publishing.
  43. Ghozali I (2008) Structural Equation Modelling: Method Alternative dengan Partial Least Square Semarang: Badan Penerbit Undip.