

Geometric and Mechanical Parameters for the Adjustment of the Preload of Differential Bearings in Gearboxes of Automobile Axles

Vasiliev AN, Vasiliev AN, SamoiloVA AS*

Department of Technology and Equipment of Mechanical Engineering, Faculty of Mechanical Engineering, Moscow Polytechnic University, Russia

ABSTRACT

This article discusses the construction of bearing units of different cars differentials and provides the analysis of technical requirements for the adjustment of the preload of bearings. There are four most commonly used methods for the adjustment of the preload. This paper defines a method for the adjustment of the preload based on deformation of bearing seats, which is the most acceptable in production and which is characterized by the least indirect adjustment and consequently the least number of failures. A formula is given for the calculation of the required preload force based on the failure in opening the joint in the unloaded bearing. A description of industrial equipment for the implementation of this method is presented.

Keywords: Bearing; Preload; Stiffness; Gearbox; Differential; Adjustment; Deformation; Methods for creating a preload

INTRODUCTION

When assembling gearboxes of driving axles of automobiles and other vehicles, the final operation of the gearbox assembly process, i.e., the creation and the adjustment of the preload of differential bearings, is one of the most complex and responsible operations that determine the assembly quality and operational reliability of the driving gear. At this stage of the assembly the required gearing parameters of the driving gear of the gearbox and the preload of the differential bearings are achieved [1].

This assembly phase is difficult to be automated and requires highly skilled assembler. The assembly failures, experienced at this stage, have a direct impact on the operational performance and the reliability of the gearbox as a whole. Figure 1 is the photograph of the differential construction. Figure 2 presents a structural diagram of driven bevel gear unit assembled with differential and bearings in the housing. The basic elements of the geometry, force factors and parameters for the adjustment of bearing preload are shown.

The inner rings of the bearings 3 are pressed onto the stems of differential cases 2. The driven gear is fixed to the left differential case 5. The driven gear, assembled with the outer rings of the bearings 3 and with the threaded adjusting rings 4, is installed into the gear housing 7 being bored in assembly with cover 1.

When installing the differential 2 in assembly with the driven gear 5

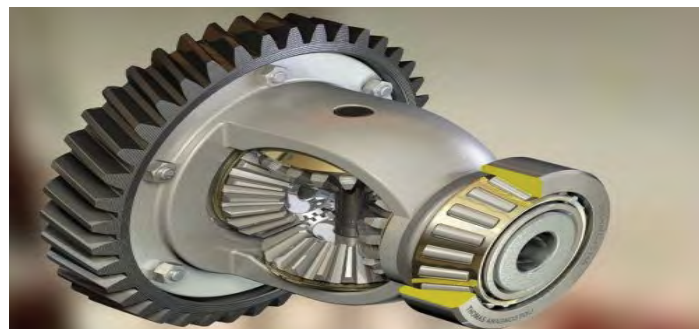

Figure 1: Differential construction assembled with bearings and driven helical gear in the case.

in most gearbox constructions, the cover 1 is to be removed having completed the marking of their location on the gear housing 7.

Using the threaded adjusting rings 4, the required interlocking parameters (lateral clearance and contact patch) in the main gear are achieved and the differential bearings preload is created and adjusted. Figure 3 is the photograph which shows tightening the adjusting rings.

The analysis of the adjustment parameters of the preload of the differential bearings in the gearboxes of various vehicles is presented in Table 1.

Table 1 show that the preload adjustment is set in the assembly

Correspondence to: SamoiloVA AS, Department of Technology and Equipment of Mechanical Engineering, Faculty of Mechanical Engineering, Moscow Polytechnic University, Russia, Tel: 79163419067; E-mail: tiger.56@mail.ru

Received: May 26, 2020, **Accepted:** July 04, 2020, **Published:** July 13, 2020

Citation: Vasiliev AN, Vasiliev AN, SamoiloVA AS (2020) Geometric and Mechanical Parameters for the Adjustment of the Preload of Differential Bearings in Gearboxes of Automobile Axles. J Appl Mech Eng. 9:327. doi: 10.35248/2168-9873.20.9.327

Copyright: © 2020 Vasiliev AN, et al. This is an open access article distributed under the term of the Creative Commons Attribution License, which permits unrestricted use, distribution, and reproduction in any medium, provided the original author and source are credited.

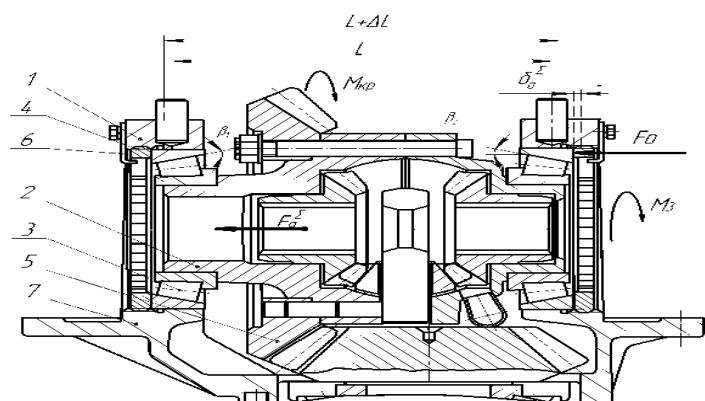

Figure 2: Structural diagram of the gear differential assembled with driven gear and bearings: 1-cover, 2-differential case, 3-tapered bearing, 4-threaded castellated ring, 5-driven gear, 6-locking element of the adjustment ring, 7-gear housing.



Figure 3: Adjustment of interlocking parameters and preload of differential bearings in the gearbox of the drive axle of automobile.

Table 1: Technical conditions for the adjustment of the preload of differential bearings in gearboxes of various vehicles.

1	Based on the deformation of seats $\Delta L=0,1...0,2$ mm Adjusting nuts are to be tightened completely with a wrench $l_{cl}=500$ mm, then they must be removed to match the nearest slot with the stopping plates. The absence of axial play.
2	Tightening of the nut $M_{cl}=300...360$ n × m. The axial displacement of the bearings of the differential to prevent the support ring.
3	Tightening of nuts of the covers not less than 250 n × m. $\Delta L=0,15...0,25$ mm
4	Differential bearings do not need to be pre-tightened and to be moved by axis.
5	$M_{\partial \partial_{\text{ав}}} = 0,2...0,3$ KGM (after removing the drive gear)
6	Based on the deformation of the seats $\Delta L=0,2$ To get the correct preload of conical differential bearing the adjustable nuts on both sides are tightened by two threads from the position of the zero axial play.
7	Based on the deformation of seats $\Delta L=0,16...0,22$ mm
8	Based on the deformation of seats $\Delta L=0,1...0,15$ mm
9	Based on joining of drive gear, up to 6 n × m
10	Based on deformation of bearing seats $\Delta L=0,1...0,2$ mm
11	Based on deformation of bearing seats $\Delta L=0,1_{0,15}$
12	Tightening of installation (threaded rings) of differential is 150 n × m (15 kgm)

requirements and it is performed according to four different parameters (note: the ΔL parameter is shown in Figure 2):

1. Based on the rotation ϕ of the castellated adjusting threaded ring (for example, two threads from the position of the "zero" axial play shown in Figure 4).
2. Based on the moment of tightening (M_3) of this threaded adjusting ring (for example, in the range from 50 ... 150 Nm).
3. Based on the moment of rotation (M_{pr}) of the differential in the bearings when the drive gear is removed or based on the increment of the moment at the drive gear when adjusting the bearings of the driven gear (for example, in the range from 1 ... 4 Nm).
4. Based on the adjustment of the preload of the differential bearings according to the deformation of the seats (ΔL) for the bearings (in the range from 0.1 ... 0.3 mm).

It should be noted that the adjustment of the preload by the fourth parameter (ΔL) is the most popular method for creation and control of axial compression of bearings. In addition, a specific feature for all presented adjustment methods is the subsequent locking of the plates in the closest thread, while the castellated adjustment ring is being tightened completely.

All the listed adjustment parameters of differential bearing preload are indirect. The main parameter of the preload, i.e., the axial compression force of the bearings which determines the required stiffness of the produced unit, is not possible to control.

These parameters differ in the degree of indirectness and availability of their control in workshop conditions.

The Department of Engineering Technologies and Equipment of Moscow Polytechnic University (Mospolytech) developed a methodology which determines the required preload force for the bearings of the driven gear of the gearbox and the interconnection of indirect parameters of the bearing preload, the design features of the gearbox and force factors arising in operation was established. To achieve the target on the basis of the constructive scheme (Figure 5) a simplified scheme has been developed for creation and adjustment of the preload of differential bearings. In this diagram, tapered roller bearings are presented as conical springs, and threaded adjusting rings are shown as screw pairs which create axial compression on the springs. Bearing preload forces and the total axial force acting on the loaded bearing from the driven gear in operation are also shown.

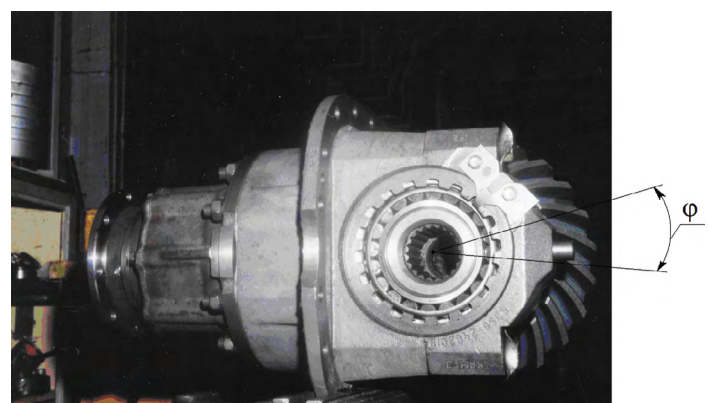

Figure 4: Differential bearing housing with threaded castellated adjusting ring and stopper.

EXPERIMENTAL PART

The degree of the preload (axial compression F_0) of differential bearing must be based on the condition of non-disclosure of the joint in unloaded bearing by axial flexibility of adjustable bearings, match of slots in the gear unit and the total axial force acting on the load bearing. The graphic image of the relationship of these parameters is shown in Figure 5 where $\Delta L = \Delta L_1 + \Delta L_2$ is the total deformation of the bearing seats of the differential under a preload [2-5].

$$\delta\Sigma_0 = \delta_01 + \delta_02 - \text{Total deformation in the bearings under a preload.}$$

In Figure 6, 1 - loaded bearing (β_1), 2 - unloaded bearing (β_2), F_1 - force of preload, β_1 - Cone angle (the angle of the running surface) of the outer ring of the loaded bearing, β_2 - Cone angle (the angle of the running surface) of the outer ring of the unloaded ring, F_a^Σ - The total the axial force in the main gear arising in the operation of the gearbox and acting on the loaded bearing, δ_o^Σ - The total axial flexibility of the differential bearings, ΔL - the axial flexibility of the seats in the gear housing.

Using the graph-analytical method and the diagram in Figure 5, the analytical equation is given for determining the required force preload in the bearing units of the differential based on the above listed geometric parameters of the axial stiffness of the bearings and the sockets for bearings of the differential. The obtained data show that the more the axial flexibility of C_1 load bearing and K_1 load bearing seat is, the more force of preload is required.

$$F_0 = F_a^\Sigma \left(\frac{\frac{C_1}{\sin^{1.8} \beta_1} + K_1}{\frac{C_1}{\sin^{1.8} \beta_1} + \frac{C_2}{\sin^{1.8} \beta_2} + K_1 + K_2} \right)^{1/m}$$

where: F_1 is the required force preload of differential bearing

F_a^Σ is the total axial load on the loaded bearing

C_1 and C_2 are constant coefficients of axial bearings flexibility, depending on the number, the length and the diameter of rollers determined by empirical dependency

$$C_{1(2)} = Z^{0.44} \cdot l_p^{0.28} \cdot d_p^{-0.18}$$

K_1 and K_2 are constant coefficients of the axial flexibility of the bearing seats, depending on the design of the housing.

m is the unit characterizing the nonlinear ($m=0,6-0,8$) or linear ($m=1$) curve of axial flexibility of the bearing and seat,

β_1 and β_2 are the cone angles of outer rings of loaded and unloaded bearing.

Z is the number of rollers in the bearing

l_p is the length of the rollers in the bearing

d_r is the diameter of the rollers in the bearing

The main impact on the flexibility of tapered bearings is produced by the cone angles of the outer rings β_1 and β_2 . The obtained analytical dependence is based on the graphic relationship of the axial elastic deformations and the axial force shown in Figure 6 while the constant coefficients C_1 and C_2 , K_1 and K_2 are determined experimentally.

Under the resulting axial force from the interlocking one of the

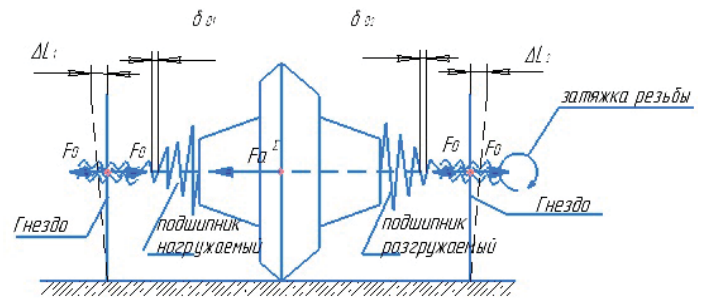

Figure 5: Simplified diagram of the creation and the adjustment of preload of differential bearings.

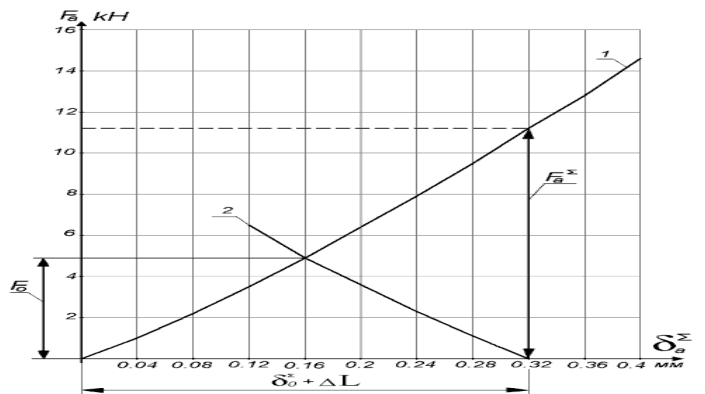

Figure 6: The relationship of total axial flexibility of the seat with axial deformation in the bearing when assembling differentials.

differential bearings is unloaded and the second differential bearing is loaded in the pre-loaded bearing unit. If there is no bearing preload in such unit, an unacceptable gap appears in the unloaded bearing which will cause noise, vibrations, and finally reduce both the durability of the bearings and the overall performance of the gearbox. A preload of the differential bearings is created in order to eliminate the possibility of such a gap.

The analysis of the design of gearboxes of various vehicles unveiled a range of angles of the outer rings of the differential bearings β_1 , $2=110...300$. As a result of the analytical research and the analysis of technical requirements for gear units in operation an estimated range of the total axial force is set taking into account the reactions in the support of circumferential and radial forces in the gearing of cars and trucks, acting on the loaded bearing.

$$F_a^\Sigma = 5000 \dots 50000 \text{ N.}$$

As a result of analytical calculations based on the above mentioned dependency Table 2 is created. Its target is to select the force of the preload depending on the cone angles β_1 and β_2 , the bearings used and the total axial force F_a^Σ load on the bearing.

In Table 2 the range of $F_a^\Sigma = 5000...10000$ N allows to determine the force of the preload of differential bearings in gearboxes of passenger cars, $F_a^\Sigma = 10000...30000$ N the force of the preload in gearboxes of trucks with average carrying capacity and $F_a^\Sigma = 30000...50000$ N the force of the preload in gearboxes of trucks with increased load capacity. The table shows that with the increase of the angle β_1 of the loaded bearing the required preload force is reduced, whereas with increase in the angle of the unloaded bearing β_2 the required force of the preload increases.

Bearings with equal angles $\beta_1 = \beta_2 = 15^\circ$ are the most frequently used among differential bearings. The range of the applied force preload is approximately 2000...5000 N (for cars) and $F_0 = 5000...7000$ H

Table 2: Measuring force of the differential bearing preload.

$F_{a \max}$ kr	β_1, rpaI β_2, rpaII	11°	15°	20°	30°
500	11°	250	220	202	187
	15°	279	250	231	215
	20°	297	268	250	234
	30°	312	284	266	250
1000	11°	500	440	405	375
	15°	558	500	462	431
	20°	594	536	500	468
	30°	625	569	532	500
2000	11°	1000	880	810	750
	15°	1116	1000	924	862
	20°	1188	1074	1000	936
	30°	1250	1138	1064	1000
3000	11°	1500	1320	1215	1125
	15°	1674	1500	1386	1293
	20°	1782	1611	1500	1404
	30°	1875	1707	1596	1500
4000	11°	2000	1760	1620	1500
	15°	2232	2000	1848	1724
	20°	2376	2148	2000	1872
	30°	2500	2276	2128	2000
5000	11°	2500	2200	2025	1875
	15°	2790	2500	2310	2155
	20°	2970	2685	2500	2340
	30°	3125	2845	2660	2500

Note to Table 2: F_0 depending on the external axial force in interlocking of conical gears of gearbox – $F_{a \max}$, the cone angles of the outer rings of the bearings β_1 and β_2 and the axial stiffness of the adjustable bearings (β_1 - Cone angle of loaded bearing, β_2 - Cone angle of unloaded bearing).

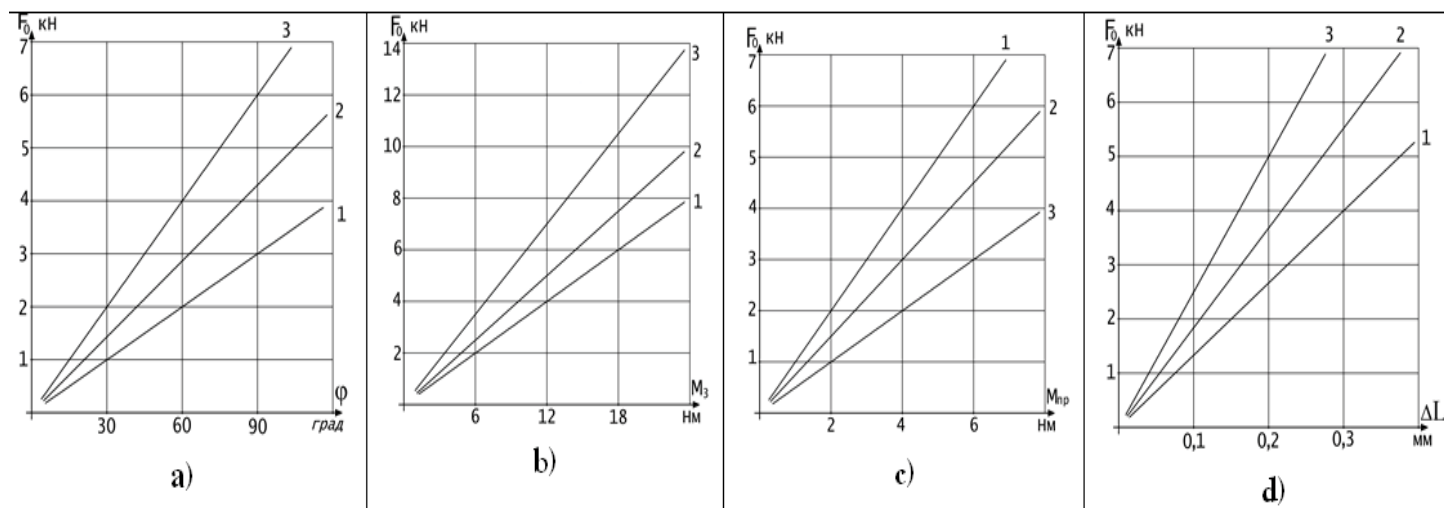

Figure 7: The relationship of the preload force in differential bearings of a gearbox and the control parameters for different methods of adjustment where a) Adjustment by the angle of rotation of the castellated threaded ring with different thread pitch (1,2,3); b) Adjustment by tightening the castellated threaded ring with different pitch and thread diameter (1,2,3); c) Adjustment by tightening the bearings with various cone angle of the outer ring (1,2,3); d) Adjustment by deformation of the bearing seats with different stiffness (1,2,3).

(for trucks).

RESULTS AND DISCUSSION

The analysis of the results shown in Table 2 outlines that the greater the stiffness of the loaded bearing (β_1) and the more the axial flexibility of the unloaded bearing (β_2) are, the smaller the minimum allowed degree of the preload (F_0) force can be accepted for the given gearbox.

In order to establish the relationship of the adjustment parameters of the preload of the differential bearings (the parameters are shown in Table 1) experimental and analytical studies were carried out and their results are shown in the graphs (Figure 7).

Figure 7a shows that the force of the preload decreases with the increase of the thread pitches of the adjusting ring. The adjustment with different diameter of the thread (Figure 7b) causes the increase of the preload force at smaller diameters. Figure 7c also illustrates



Figure 8: Technical equipment for the adjustment of the preload of differential bearings in the drive axle gearbox in real production.

the rise of the preload with growing cone angle of the outer ring of the bearing. The increase of the preload is repeated with the adjustment of the preload on the deformation of the seat with growing stiffness (Figure 7d).

Figure 7d represents the relationship of force preload and the deformation of the slots where the differential bearings were installed for different gearboxes. The dependence has a linear character and a minimum variation for one type of the housing. For the creation of the preload (4000-6000H) it is necessary to provide and register a linear deformation of 0.2 mm, which is achievable with the help of the universal measuring equipment in manufacturing conditions.

When adjusted by this method, the probability of creation of “false preload” is excluded and special measuring and technological equipment allows determining the deformation of the seats by the adjustment of the preload with an accuracy of 0.01 mm [4-12].

Based on this model special industrial equipment was developed at the Department of Engineering Technologies and Equipment in Mospolytech. It is a control clip for the adjustment of the preload of the differential bearings of the drive axle gear, shown in Figure 8. This equipment consists of a special eccentric clamp for fixing the clip on one bearing seat, which is used as a measuring tool, and a dial indicator with the scale of 0.01 mm is installed on the opposite side of the bracket. The stem of the indicator touches a flat surface of the second bearing seat using a balanced lever. Rotating the threaded adjusting rings there is a bearing compression and deformation of bearing seats (the jaws) which is registered by the indicator. The alternate rotation of bearings from side to side is obligatory for the process of bearing adjustment.

CONCLUSION

The analysis of technical conditions for the assembly and interrelation of the factors of the adjustment of the bearing preload, which is the most important parameter of qualitative gearbox

assembly, shows that the bearing preload of the differentials in the design documentation is nominal and indicative, without any analytical or experimental basis. The relationship of adjustment factors in each particular case has not been studied completely or enough in technological processes of gearbox assembly. Technological processes lack proper equipment and the required accuracy of adjustment of bearing preload is achieved through the experience and intuition of the assembler.

REFERENCES

1. Shandrov BV, Bulavin IA, SamoiloVA AS. Improving quality of assembly of bearing units based on adaptive management of adjustment of bearings. Prom-engineering: International scientific and technical conference May 15-18, 2018, Moscow, Russia, South-Ural State University-Moscow Polytechnic.
2. Bulavin IA, SamoiloVA AS, Brezhnev IA. Technological provision of preload of bearings using deformable spacers, Moscow, Bauman MSTU. Student Spring 2018, Engineering Technology.
3. Bulavin IA., SamoiloVA AS, Mochalova TS, Bobyr AS. Technological provision of bearing preload using deformable spacer elements Moscow, October 19-20, 2017-Moscow Polytechnic University, 5th International Scientific and Technical Seminar, 2017;208c.
4. Shandrov BV, Bulavin IA, SamoiloVA AS. Factors determining the quality of gears of drive axles of vehicles. Scientific and technical journal "Automotive Industry", 2017.
5. Bulavin IA, Gruzdev AYU, Budykin AV. The influence of force and deformation factors in the assembly of bearing units of automobile gearboxes on the accuracy of adjustment of bearing preload. The machine builder, 2009.
6. Bulavin IA, Gruzdev AYU, Budykin AV. The influence of forces and deformations of links in the assembly of bearing units of automobile gearboxes on the accuracy of adjustment of the bearing preload. Scientific and technical Journal of Engineering. 2009;pp:32-36.
7. Bulavin IA, Budykin AV. Improving accuracy of assembly of preloaded bearing units in gearboxes of driving axles of automobiles. International Symposium "Automotive Engineering 2009" 65th International Scientific and Technical Conference AAI "Priorities for the development of domestic automotive engineering and training of engineering and scientific personnel." Electronic Publication.
8. USSR author's certificate for invention No. 1733944, author I. Bulavin: "Method for creation of axial preload in a bearing unit". Registered in the State Register of Inventions of the USSR January 15, 1992.
9. Bulavin IA. USSR author's certificate No. 1250891 "Method for measuring length of compensating sleeve when assembling gearboxes".
10. Bulavin IA, Voronin AV. USSR author's certificate No. 1157286 "Method for installation of a rolling bearing in a housing", 1985.
11. Shandrov BV. Research of some technological factors of assembly of drive gears of cars. Diss Cand Tech Sciences. 1974; p.140.
12. Bulavin IA. Technological provision of adjustment accuracy of bearing preload in gearboxes of drive axles in automobiles. Diss Cand Tech Sciences. 1983; p. 240.