

Design and Analysis of a Pedal Operated Washing and Drying Machine

Hakizimana E*, Masengesho P, Cyusa O, Niyigena M

Department of Mechanical and Energy Engineering, University of Rwanda, PoBox 3900, Kigali, Rwanda

ABSTRACT

Pedal-operated washing and drying machine (POWDM) is an inexpensive/cut rate washing and drying machine buildup of simple and reliable available scrap parts in our everyday life and it is looking like a commercially available horizontal axis washer. It is a machine designed in the way that produces power over human pedaling and the drive mechanism; alters that motion into essential rotary motion of the internal drum. The modernization of this machine is revealed in the design simplicity. Its affordable parts, low cost of maintenance, most of all it is cheap so that everyone should afford it and it can have no impact on the environment. We proposed this to solve the issue of washing clothes and design a new generation for everyone in washing and drying clothes. POWDM is a new idea, which should do wash clothes like the automatic washing machine available in the market, with the specification of drying immediately after washing. Current techniques for washing clothes do not function well in underdeveloped rural areas. Lack of electricity makes electrical washing machines unfeasible. The proposed and designed pedal operated washing and drying machine is a leader because it solves the clothes washing and drying problems in an effective, inexpensive and practical way.

Keywords: Drying; Rinsing; Washing

INTRODUCTION

Washing machines designed in developing societies don't meet the successful requirement, because it requires electricity to perform the useful task; and the type of pedal operated washing machine takes a long time and more energy to complete the sequence that's why pedal operated washing and drying machine is introduced to help everyone to minimize the time taken by washing clothes as well performing physical exercises by pedaling while washing and the pedaling motion produce energy through the bicycle dynamo attached to the rear wheel. The energy produce compensates in the last stage of drying which results in a short time taken to wash clothes. According to the government plan, we must improve condition life of the population by ourselves as our program of made in Rwanda said, pedal operated washing and drying machine have the great contribution for this plan as it is much more reliable and efficient to wash clothes and it requires fewer effort due to the speed variation related to every sequence. At the end of the research, we put in action what we had searched, it helps the researchers to increase knowledge about pedal operated washing and drying machine and providing the way of construction easily and its differences from other washing machines; the benefit of pedal operated washing and drying machine has to the population of Rwanda and also the benefits of the research.

RESEARCH METHODOLOGY

Cloth washing is one of the important parts of life but it is considered undesirable because of the contribution of efforts, time, energy and cost. Currently, the wide variability of washing machines is available but they are electric power-driven and the basic principle of their process depends upon the creation of the turbulent flow of cleansing agents around the dirty clothes. In our country the people are living with insufficient financial capacity, to afford a washing machine because of cost limitations and electricity is not distributed all over the places and it is costly to where already distributed and maintenance is very expensive. There are some other several ways established before solving the problem by designing washing machines [1].

One of the designed machines used nearby accessible materials and secondhand bicycle parts, since the parts are broadly obtainable, the Washing machine can help as a source development. it was designed in the way that the worker doesn't need to lean over the washing basin and sink hands in the water contains soap, but he/she takes a seat over the machine and pedals to wash clothes. Unfortunately, the frame used as a seat while washing is not suited for women and the required rotation speed is limited from 50 to 500 rpm; another weakness of this design is that while pedaling it vibrates due to the use of wood fastened to metals using bolts. That's why the project should not be more suitable for everyone [2].

Correspondence to: Hakizimana E, Department of Mechanical and Energy Engineering, University of Rwanda, PoBox 3900, Kigali, Rwanda, Tel: 250783587744; E-mail: haki2012eustache@gmail.com

Received: October 23, 2020, **Accepted:** November 12, 2020, **Published:** November 19, 2020

Citation: Hakizimana E, Masengesho P, Cyusa O, Niyigena M (2020) Design and Analysis of a Pedal Operated Washing and Drying Machine. J Appl Mech Eng. 9:338.

Copyright: © 2020 Hakizimana E, et al. This is an open access article distributed under the term of the Creative Commons Attribution License, which permits unrestricted use, distribution, and reproduction in any medium, provided the original author and source are credited.

A Hand and foot-operated washer machine which uses the available materials to wash clothes with low water quantity, with low purchased and maintenance cost which is simple and easy to be used are established to wash clothes without time consuming, with power saving. Even though it overcame washing with hands, the washed clothes need to be dried with the help of the sun. In times the sun doesn't shine, it took a couple of days to dry [3]. Another pedal operated washing machine designed, provide the same solution as normal operated machine's advantages such as washing any type of clothes without soapy water and hand contact, and the machine can wash, rinse and spin dirty clothes. It was a manually driven and somehow low-cost machine that operates in the absence of electricity. The designer has chosen to use a gearbox assembled with a scrap of normal automatic washing machine (tub in frame) to generate high speed for rinsing and spinning but this leads to complexity. The energy is also lost in washing while pedaling is not kept. This causes the effort requirement during drying and decreases the overall capacity of the machine as more energy will require time and high pedaling rate during spin-drying. The designed solution leaves some water content in the clothes as we cannot produce very high rotation of drizzly clothes so that moisture can be separated due to centrifugal action [4]. The designed machine is composed of different materials and equipments as indicated in the Table 1 and the design specification is also summarized in Table 2.

Working principle of pedal operated washing and machine

In this study, the rotation of drumming is possible through sprocket rotation. Sprocket is rotated by a chain drive. Once an operator starts peddling, the gear linked through the sprocket chain starts to transmit power. The rotation of the drum is dependent on input power and the complete process depends on the compound gear system. Gear drive is a way of transmitting mechanical power from one place to another. Sometimes a convey power is used to the sprocket of a bike, mostly bicycles.

Furthermost, the power is taken by a roller chain, known as the drive chain or transmission chain, passing over a sprocket gear, with the teeth of the gear engaging with the holes in the links of the chain. The gear is turned, and this pulls the chain putting powered force into the

Table 1: Tools, equipment's and materials.

Materials	Tools and equipment
-Round bar	- Files
-Tubes	-Spanner
-Sheet metal	-Hammer
-Bearing	-Scribers
-Chain	-Lathe machine
-Flat bar	-Drilling machine
-Bolts and nuts	-Grinding machine
-Sprocket	-Electrodes
-Sprocket pinion	-Taper measure
-Angle bar	-Cutting and grinding disk
-Bicycle seat	
-Pedal	
-Dynamo	
-Electrical resistor (Heater plate)	
-Battery	
-Wire cables	

Table 2: Dimension and specification of components.

Components	Dimension	Specification
Bearing	35	Carbon iron and mild steel
Bolts	M8	Mild steel
Shaft	Ø 20,500 mm	Carbon steel
Sprocket	1Ø2 Inch pitch	Mild steel
Inner drum	Ø 400,500 mm	Aluminium
Outer drum	Ø 450,510 mm	PVC
Bike frame	168-175 cm, rider height	Aluminium

system. Sometimes the power is output by simply rotating the chain, which is used as input for the washing drum. In other situations, second gear is placed and the power is improved by attributing shafts or hubs to this sprocket pinion. Open the outer and inner drum doors and put the clothes in the inner drum and close the inner door. About 42 liters of water and add detergent, close the outer door and sit on a comfortable chair. Begin to cycle starting slowly and increasing pace. Pedal for about 40-45 minutes. Remove the soapy water by opening the drainage screw at the bottom of the outer drum and add rinsing water and pedal for a short time. Remove the water. Drying will require a faster pedaling rate. The heat in the drum will also help dry the clothes and after remove the clothes from the machine. A preventative type of maintenance every 3 years is more suitable. The components that require replacement are the sprocket, gears and the chain. The designed machine has to be greased and maintained at regular intervals.

Design specification

The most important consideration in the design of the machine is the ability to perform as a device that makes the task of washing clothes in the easiest ways. In order to be a viable solution in rural areas, the proposed machine should deliver the same quality of washing in terms of use, the clothing wear and the effort required to perform washing operations. If this machine is to be used at home, the machine should be close to the water source for the operation. The set of specifications for sizing, use water, and load sizing depends on the targeted group. The important design specification of POWDM is the following:

- Cleaning:** The washing and drying machine should be as clean as the operator's hands
- Gentleness:** It must wear clothes at a slower rate than washing by hands
- Capacity:** Maximum clothes/load of 2 kg
- Water use:** Maximum 10 L of water per 1 kg of clothes
- Active pedaling time:** The maximum min washing, min rinsing, min drying for the effective washing.
- Total operation time:** Maximum operation time is min including fetching water, cleaning and draining.
- Power:** 100 W for pedaling an hour (for an adult of a good fit, power is between 50 W and 150 W)
- A Lifetime of structure:** Three years, assuming daily use
- Materials:** Local materials including wood, weldable metal, bicycle parts, etc.
- Dimensions:** Less than the combined size of the bicycle and the commercial washing machine

11. Weight: Maximum weight of the driver/operator should not exceed 100 kg

12. Culturally acceptable: This machine has a suitable appearance and suitable seat for the women that use the machine.

RESULTS AND DISCUSSION

Modelling and simulation

POWDM is the machine that transfers the energy from a human effort through the use of a foot pedal and chain system. This technology is most often used for transportation and has been used on bicycles for over many years ago. The designed machine is composed of different materials such as bolts, sprockets, shaft, bearing, angle bar and tubes. The general assumption and calculation used for designing machine are:

Load of a person sitting on a machine = 100 kg = 100 × 9.81 = 980 = 1000 N

Normal paddling RPM = 60-100 rpm

Force applied at paddling = 50 kg = 5 × 9.81 = 49.05 = 50 N

A normal person applies 60-100 rpm in normal working conditions [5-9]. As per this assumption, we design the transmission of a system based on washing, rinsing and drying mechanisms, in order to calculate the speed of sprocket pinion we use maximum rpm.

For drying, the diameter big sprocket $D_1 = 300$ mm

Number of teeth of the rear big sprocket, $T_1 = 40$

Number of teeth of rear sprocket $T_2 = 8$

Rotation speed required for drying, $N_{s2} = 600$ rpm

The rotation speed of big sprocket required to obtain the rotation speed of the drum is given by

$$N_{s1} = (N_{s2} \times T_2) / T_1 = (600 \times 8) / 40 = 120 \text{ rpm}$$

The pitch diameter of the big sprocket is given by

$$D_1 = p \operatorname{cosec} (180 / T_1)$$

$$300 = p \operatorname{cosec} (180 / 40),$$

$$p = 23.54 \text{ mm}$$

The diameter of rear sprocket is given by,

$$d_2 = 23.54 \operatorname{cosec} (180 / 8) = 61.513 \text{ mm}$$

For rinsing, the required rotation speed $N_{s2} = 400$ rpm

Number of teeth on the rear sprocket, $T_2 = 8$

The diameter of the rear sprocket, $d_2 = 61.513$ mm

Speed of rotation of the medium sprocket $N_{s1} = 60$ rpm

Number of teeth of medium sprocket is given by $T_1 = T_2 \times N_{s2} / N_{s1} = (8 \times 400 / 60) = 53.33$ teeth

The diameter of the medium sprocket is given by $d_1 = 23.54 \operatorname{cosec} (180 / 53.33) = 240.16$ mm

For washing, the required speed of speed $N_{s2} = 40$ rpm

Number of teeth of rear sprocket $T_2 = 8$ teeth

The diameter of rear sprocket $d_2 = 61.513$ mm

Number of teeth of the small sprocket, $T_1 = 20$ teeth

$$N_{s1} = (40 \times 8 / 20) = 16 \text{ rpm}$$

$$d_1 = 23.54 \operatorname{cosec} (180 / 20) = 150.48 \text{ mm}$$

A shaft is subjected to both bending and twisting moment we design it by maximum shear stress (for ductile such as mild steel) or by maximum normal stress theory (for brittle material such as cast iron), so our shaft is made in mild steel means is designed to maximum shear stress A normal person applies 100 rpm with the power of 100 W and the maximum permissible shear stress may be taken as:

- 56 MPa for shafts without allowance for keyways
- 42 MPa for shafts with allowance for keyways

The overall allowable working stress can be taken as:

- ▶ 112 MPa for shafts without allowance for keyways
- ▶ 84 MPa for shafts with allowance for keyways [10]

Consider the case for drying (where we have a high speed of rotation)

$$P = 100 \text{ W}, N = 600 \text{ rpm}, r_2 = d/2 = 30.756 \text{ mm}$$

The torque is given by $T = 60 \times 100 / 2 \times \pi \times 600 = 1.5915 \text{ Nm}$

$T_1 \cdot T_2 = P / \omega$, where

$$\omega = \pi \times D \times N / 60 \quad (\pi \times 600 \times 0.061513 / 60) = 1.932 \text{ m/s}$$

$$T_1 \cdot T_2 = 51.75 \text{ N} \dots \dots \dots (1)$$

$T_1 \cdot T_2 = e^{u\theta}$, where

$$u = 0.35$$

$$\theta = (180 - 2\alpha) \times \pi / 180, \text{ and } \sin \alpha = (r_1 - r_2) / x, \text{ where}$$

$$x = 410 \text{ mm and } r_1 = 150 \text{ mm}$$

$$\alpha = 16.9^\circ \text{ and } \theta = 2.55$$

$$\text{Then, } T_1 / T_2 = 2.442 \dots \dots \dots (2)$$

By solving equation (1) and (2), we get $T_1 = 87.64 \text{ N}$ and $T_2 = 35.87 \text{ N}$

$$\text{Weight} = T_1 + T_2 = 123.51 \text{ N}$$

Bending moment acting on the shaft is given by = Weight Length of the shaft = 61.754 Nm, where Length of shaft = 500 mm

When shaft subjected to combined twisting moment and bending moment, for maximum shear stress with allowance for keyways).

1. When a shaft is subjected to twisting moment, the equivalent twisting moment is given by,

$$T_e = (M_2 + T_2) / 2 = \pi / 16 \times \tau \times d^3 = 61.774 \text{ Nm}$$

$$d^3 = (61.774 \times 16) / (\pi \times 42 \times 10^6)$$

$$d = 19.56 \text{ mm (standard diameter is 20 mm)}$$

2. When shaft subjected to bending moment

The equivalent bending moment is given by,

$$M_e = 1/2 (M + T_e) = \pi / 32 \times \tau \times d^3$$

$$M_e = 1/2 (M + T_e) = 61.764 \text{ Nm}$$

$$d^3 = (32 \times 61.764) / (\pi \times 84 \times 10^6)$$

$$d = 19.56 \text{ mm (The standard diameter is 20 mm)}$$

Seat

A seat is placed to sit; seat is an arrangement in any bicycle on which a person can sit comfortably. In the seating arrangement, the design factor is always considering according to their use. The seat may be made of plastic, rubber (Figure 1).

Pedal

A bike pedal is the portion of a bicycle that the operator thrusts with the foot to drive the bicycle. It delivers the linking between the cyclist's foot or shoe and the crank permitting the leg to turn the bottom bracket spindle and drive the bicycle's sprocket. Wheels were primarily attached to cranks on connecting directly to the drove (usually front) wheel. The protection bicycle, as it is identified today, came into being when the pedals were attached to a crank driving a sprocket that transmitted power to the driven shaft using a roller chain (Figure 2).

Sprocket with pedal link

Sprockets and pedal links are connected to transmit rotary motion to the shaft connected on the inner drum with the help of a chain. Three different sprockets are according to the task purpose. The large, medium and small sprocket is meant for drying, rinsing and washing respectively (Figure 3).

Shaft

The shaft is the main driving element. The shaft material selected is mild steel solid shaft in order to optimize the cost. The shaft is a coated wall a layer of oil paint so that the shaft is rustproof. The shaft diameter chosen is 35 mm and is simply supported by bearings, the shaft is analyzed and calculation is done to check it against bending moment and torsional moment, the analysis determines that the stress values are well within the permissible limit. The shaft is a power-driven element for transmitting torque and rotation, usually used to connect other mechanisms of a drive train that cannot be connected directly because of distance or the need to allow for relative movement between them (Figure 4).

Speed variator

The speed variator is normally used to change the speed according to tasks. It does this by changing from one sprocket to another. The bigger sprocket, high speed of rotation and smaller sprocket transmits low speed of rotation. It directly connects to the sprocket with the help of a chain mechanism (Figure 5).

Chain

When creating your own human-operated bicycle, a chain drive will likely be your chosen power transfer system, as it is an inexpensive, easily-to-install and extremely effective drive mechanism. Bicycle chains are equitably simple, requiring unique one cheap tool to remove and attach links. Two types of bicycle chains are available: single speed chain and multi-speed chain. The single-speed chain is primarily used on children's bikes, coaster footbrake, and weighty cargo bikes. The multi-speed chain is used on standard speed bikes and mountain bikes that require the use of a front and rear derailleur to change gears. The chain drive can transmit motion to several shifts by one chain only and the production cost of chains is relatively high.

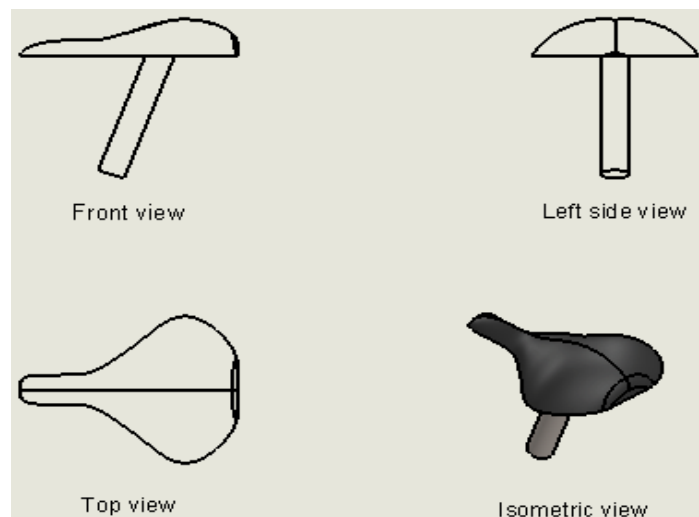

Figure 1: Seat and its views.

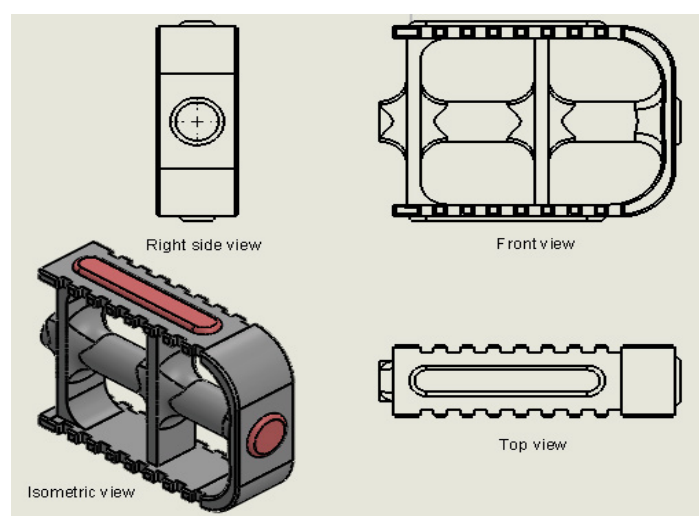

Figure 2: Pedal and its views.

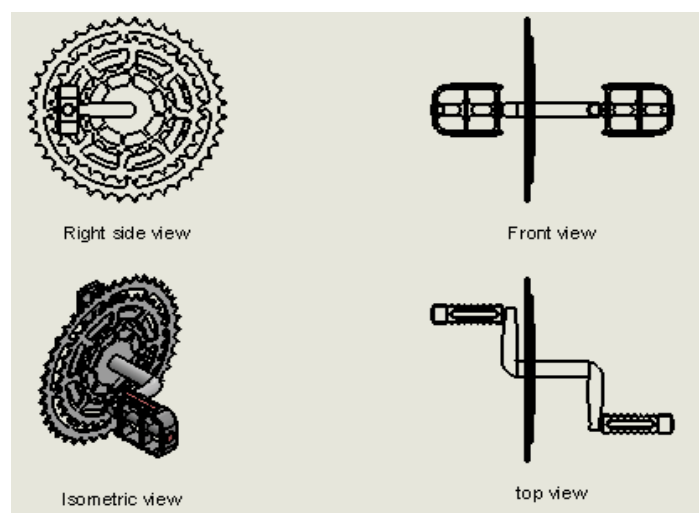

Figure 3: Sprocket with pedal link and its views.

Bike frame

The bike frame is the key component of a bicycle, on which its fits other apparatuses. The up-to-date and most public frame design for a standing bicycle is built on the secured bicycle. Frames are essential to be strong, inflexible and bright, which they do by combining unlike materials and shapes and it makes the frame of

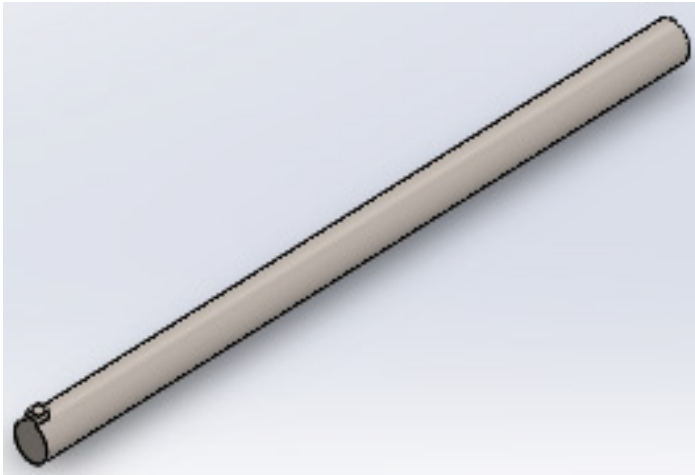

Figure 4: Shaft.

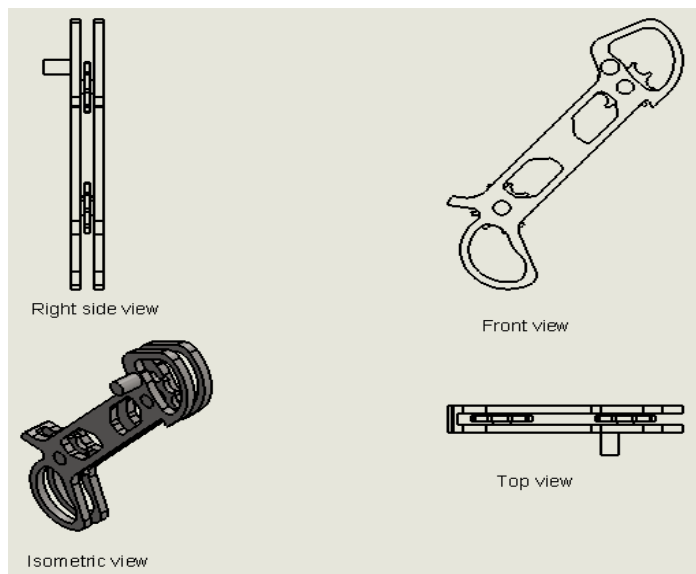

Figure 5: Variator and its views.

aluminum since aluminum is not very dense so it can be formed into lightweight structure. The bicycle has a different number of simple machines like wheels, brakes, gears and pedals that help the bike to move. When the rider pedals the wheel(s) rotates as shown in Figure 6. The bicycle has a “tool” that enables moving the support and control the bike in balance. That tool is the steerer, split to be careful. The bicycle junction is always at an angle. It is never (fully, 90 degrees) vertical. The junction angle is not for fashionable purposes but has a significant role. It permits movement of the pivot and equilibrium care. When bars are curved to the right, the front controls contact point is also stirred to the right. This moves the pivot to that side as well. as shown in Figure 7.

Drum as a washing chamber

It is just a chamber in which water is filled with detergent further clothes are put inside to be washed, rinsed and dried. In this type of machine, there are two drums are used: inner & outer. The inner drum consists of clothes and it is less in diameter as compared to the outer drum. The inner drum is flanked throughout its body. It rotates with the help of compound gear and chain arrangement at the desired speed with respect to the purpose as shown in Figure 8. Outer drum is used to store water used for washing and rinsing the clothes as shown in Figure 9.

Working principle of the electrical part

The pedaling power is converted into electrical energy by the dynamo, the dynamos are connected into series in order to charge the battery. The dynamo of 12 V cannot charge a battery of 12 V, which is why they are in series connection. The charge controller controls the voltage or current produced, the function of the battery is to store the output of the dynamo. The electrical plate converts the electrical energy into heat. The general structure of the electrical working principle is shown in Figure 10.

Assembling

The cycle frame consists of the sprocket, chain, catcher, pedal, etc. With the help of SMA welding, the stand & seat is mounted to the frame. The seat & stand is made of rubber and metal. Pedaling gear is connected to the sprocket with the help of a chain. The sprocket pinion is mounted on the same shaft, so the speed of sprocket & sprocket pinion is the same. This big gear transfers this rotary motion to another gear which is much smaller than this gear. This assembly of gear with the chain is known as a compound gear system. This small gear is coupled with a washing chamber (i.e., drum) by using fasteners. In this procedure, the productivity

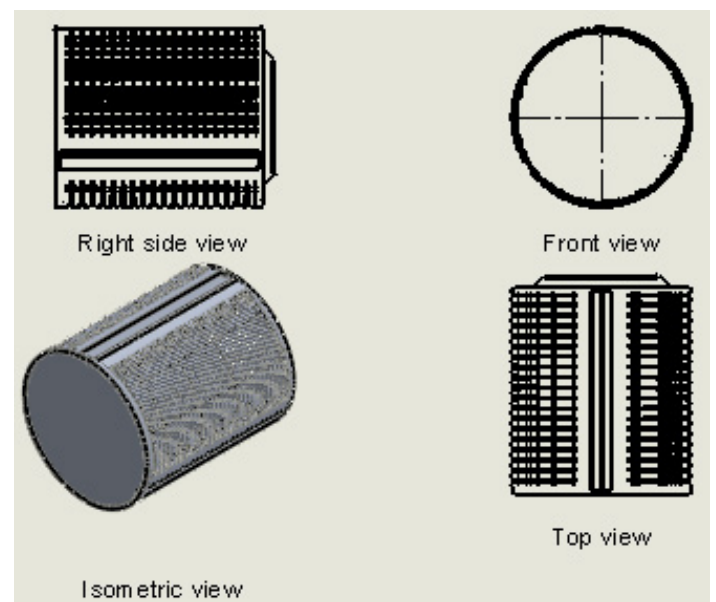

Figure 6: Bike with support.



Figure 7: Bike junction viewpoint.

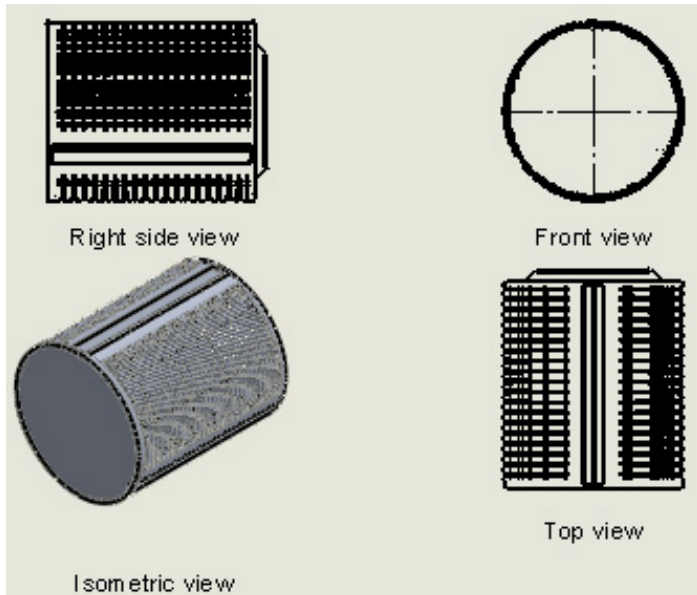

Figure 8: Inner drum and its views.

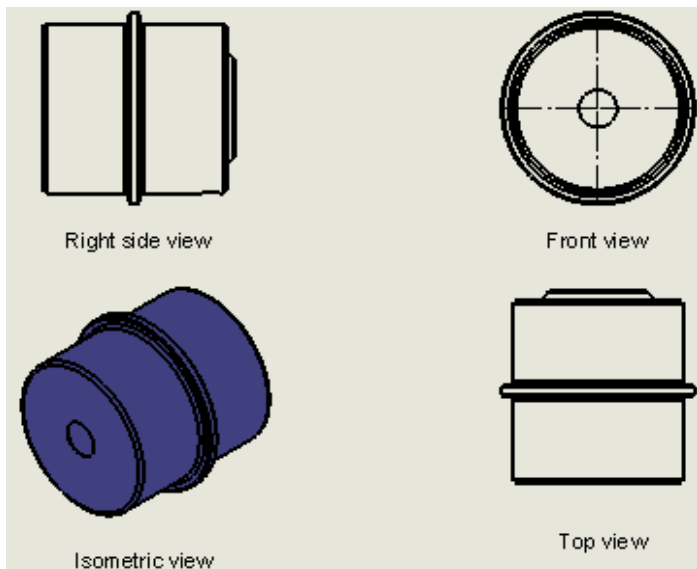

Figure 9: Outer drum and its views.

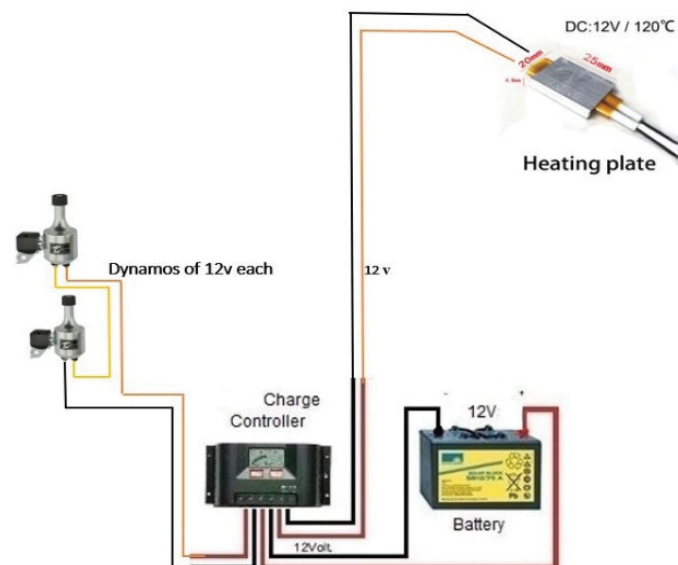

Figure 10: Electrical part of the model.

is much bigger than the input specified in the form of pedaling motion. There are two drums are mounted on that output shaft; outer & inner drum. The inner drum contains clothes and water & it rotates at the same speed that of gear. The outer drum consists of water only & it is stationary. The inner drum rotates freely without any obstacle [11-15].

The steel base frame comprises of this whole arrangement. The nuts and bolts are used to fix this assembly and it gives the rigidity to the whole structure. To give the aesthetic appearance to the machine, the steel plyboard is used to make the housing. This housing protects the outer drum perils of outsiders. For washing, the speed is quite low & for drying, the higher speed i.e., rpm is required. This speed can be attained by a normal person. The assembled model of pedal operated washing and drying machine is shown in Figure 11.

The displacement result type used to show how much our model will deflect or displace when the loads and the supports are applied. The areas of the model that the red has the most displacement. The displacement of our model will vary between 0 mm and 0.2339 mm. The displacement effect of the model, when subjected to load will reduce down the model support as shown in Figure 11. The reaction force acts in a direction opposite to the active force. The reaction force of this study varies between 0 and 151.9 N and it acts on the bike support as shown in Figure 12. The stress analysis helps to see how the materials and structures react under the load

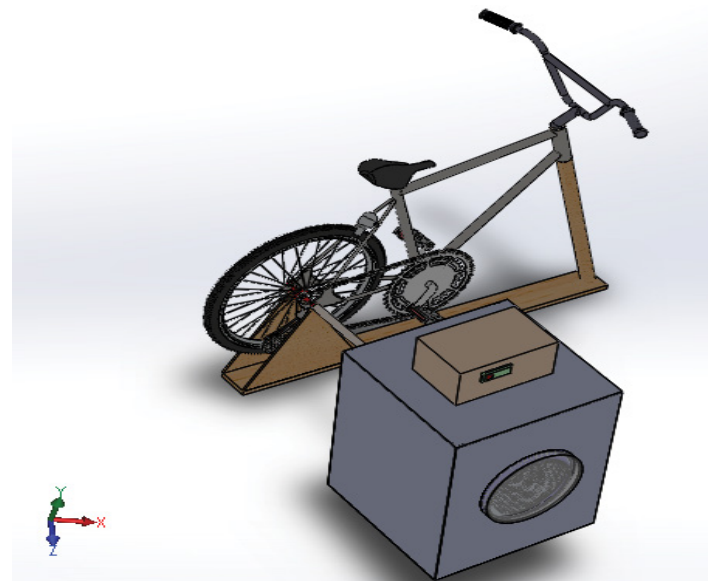

Figure 11: Assembled of the designed machine.

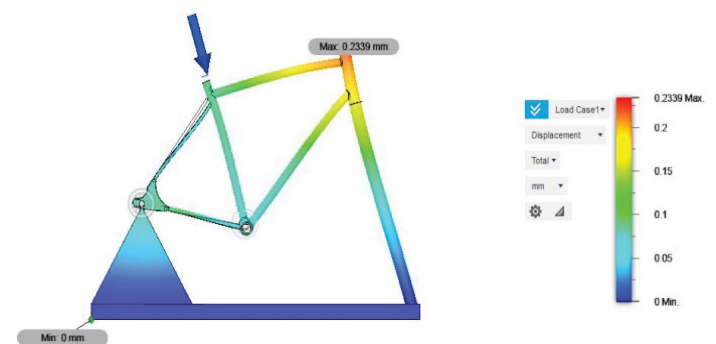

Figure 12: Displacement simulation of bike frame and support.



Figure 13: Stress simulation of bike frame and support.

Table 3: Cost estimation of the designed machine.

Components	Specification	Quantity	Unit Price	Total price
Bike seat	-	1	8000	8000
Steering	-	1	5000	5000
Wheel	-	1	25000	25000
Shaft	Ø 20,500	1	10000	10000
Dynamo	12V,6 W	2	10000	20000
Electrical resistor (Heater plate)	12V,120°C	1	1800	1800
Battery	12V,2200 mAh	1	40000	40000
Inner and drum	-	1	219494	219494
Washing machine cover	515 × 515 × 670	1	30000	30000
Sprocket pinion	Ø 65,8 T	3	3000	9000
Pedal	-	2	1000	2000
Electrodes	Ø 2.5	1	3500	3500
Cutting disc	Ø 230	1	2000	2000
Grinding disc	Ø 180	1	2000	2000
Bearing	P 207	5	6000	30000
	Total			407,494 Rwf= 427.74 USD

applied by the rider on the bike frame and determine the reliability of the structure or the model. Stress analysis of our model shows the load applied to it has a low impact on the model. Stress is varying between 1.505×10^6 MPa and 55.38 MPa as shown in Figure 13 and the estimated cost of the designed machine is summarized in Table 3.

CONCLUSION

The machine must be inexpensive and easy to build. The machine will only contain parts that are available in rural areas. This eliminates the need to order or import components just for the washing machine. The machine also uses bicycle parts for all the precision parts. The pedal operated washing and drying machine is quite different from the community's current method of washing clothes; the community may be unwilling to try the new machine. They have already proved they are willing to try new technologies. Their support will greatly increase the credibility of the machine so that local people will be ready to try it. We achieved what we desired i.e., to build a manually driven pedal operated low-cost washing machine using locally available materials and performing the necessary function of washing and rinsing with ease. The designed washing machine doesn't consume electricity. The washing machine can be used by urban people also while workout and exercises. It can serve dual purposes. While cycling, clothes can be washed utilizing the pedaling of the human being.

REFERENCES

1. Krishnamurthy M, Rakshith KK, Harshaa R, Rakesh N. Pedal operated washing machine. *Int J Eng.* 2017;12:60-66.
2. Ajay RS, Jadoun KC. Design and fabrication of manually driven pedal powered washing machine. *Innovative System Design and Engineering*, 2014.
3. Ncoro E. Human-Powered washing machine project.
4. Ranjan A, Sharan K, Mazumdar S. Pedal powered washing machine. *Int J Sci Res.* 2014.
5. Dharwad CK, Tandle P, Shiypuje S, Ladkat S, Simiran K. Design of washing machine for cleaning of small components. *IJEERT*, 2015;30-36.
6. Bahale SG, Await A, Saharkar SV. Design and fabrication of a pedal operated washing machine, *Ideal Institute of Management and Technology*, Mumbai, India. 2015.
7. Gert JW, Paul VG, Henk S. Design and development of pedal driven washing machine. *International journal of Engineering and Technology Research.* 2016;2:15-34.
8. Tawanda M, Tererai JM, Charles M. Design and fabrication of a pedal powered washing machine, in *Proceeding of the international conference on industrial Engineering and operations Management*, Bogota, Colombia. 2017.
9. Bernard T, Vercruyssen F, Grego F, Hausswirth C, Lepers R. Effect of cycling cadence on subsequent 3 km running performance in well trained triathletes, in *cycling cadence and running performance*, Paris, UFR STAPS, 2003;154-159.

10. Khurmi RS, Gupta JK. Machine design. Eurasia Publishing House, New Delhi (Pvt.) Ltd., 2005.
11. Wilson DG. Understanding pedal power, 4th edn, Vol. 2, G. W. O. K. T. Y. M. J. David, Ed., Virginia, USA, Volunteers in Technical Assistance (VITA). 2012;740-741.
12. www.Alibaba.com, Alibaba Group Holding Limited, China.
13. Teresa B, Stephanie D, Harrison K, Jessica V, Alexander Y. Pedal powered washing machine, IDEAS 2009 Proposal, Chimaltinango. 2009.
14. Make a washing machine drum fire pit. [Film]. USA. 2017.
15. Jegan MP, Kumar M, Arjun A, Dhandapan S. Design and fabrication of portable washing machine, International journal of Research in applied science and Engineering Technology (IJRASET). 2019.